

Hidden *p*QA

Portable Quadrupole Analyser

for Environmental Monitoring Applications in the Field



Introduction

The *pQA* Portable Quadrupole Analyser is a Mass Spectrometer System configured for environmental measurements in the field.

The system combines the real-time quantitative analysis of **dissolved or evolved gases and vapours** in a mobile case running from a 12 or 24 volt electrical supply. This innovative and compact packaging allows the *pQA* to be taken into the field for *in situ* measurements, providing a distinct advantage in time and efficiency over traditional analysis methods.

The *pQA* system has a mass range of 200 amu with detection to **sub ppb levels**.

Introduction

*p*QA Case Dimensions:

W: 795 mm, D: 518 mm, H: 394 mm

Weight: <40 kg

Equipped with an extending handle and base wheels for easier mobility.

Hiden HAL 201 mass spectrometer providing excellent detection and robustness.

Range of membrane Inlets (MIMS) for optimal analysis.



pQA Technology

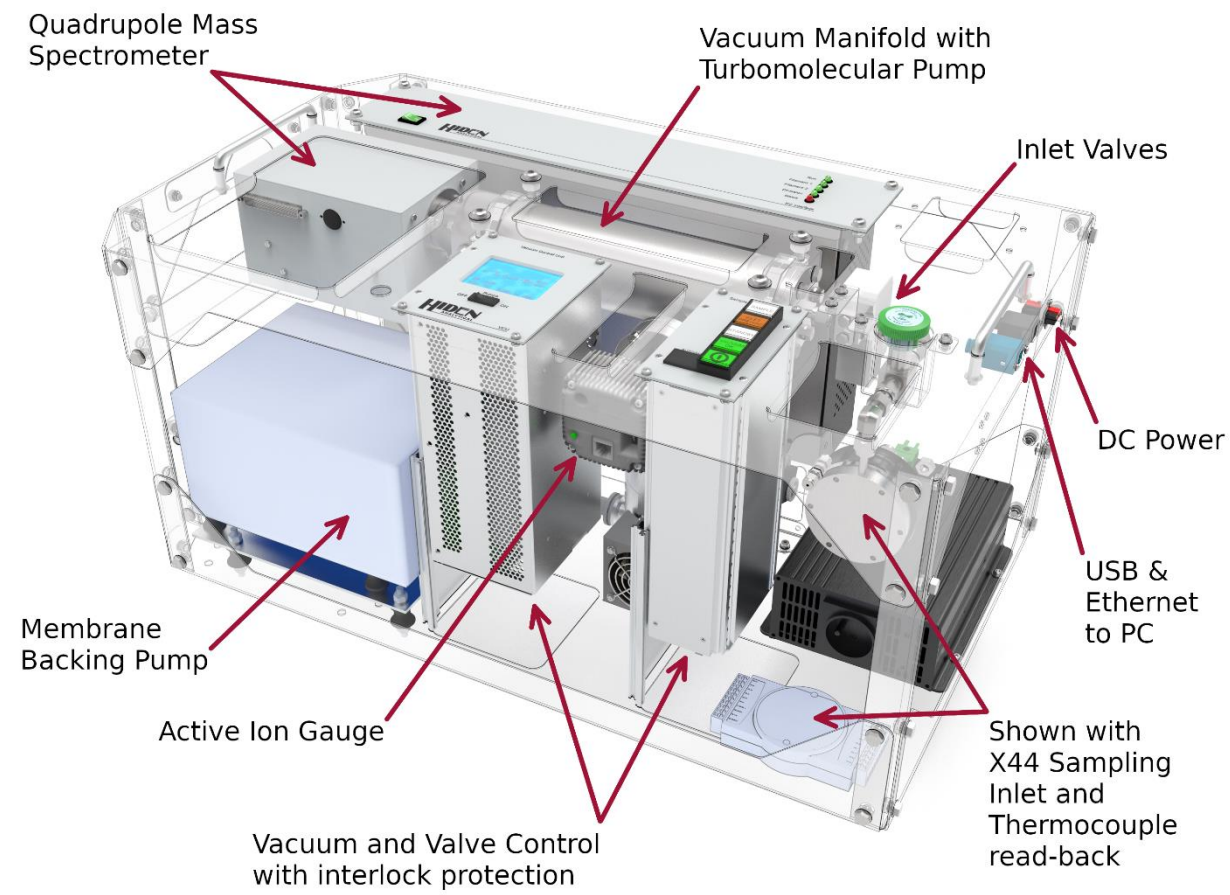

Applications of *pQA* system

- Environmental monitoring
- Soil core analysis
- Water analysis in Reservoir, River, Estuary or Sea.
- Groundwater studies
- Contamination tracking
- Microbiological / Enzyme activity studies
- Swimming pool analysis



MIMS Overview

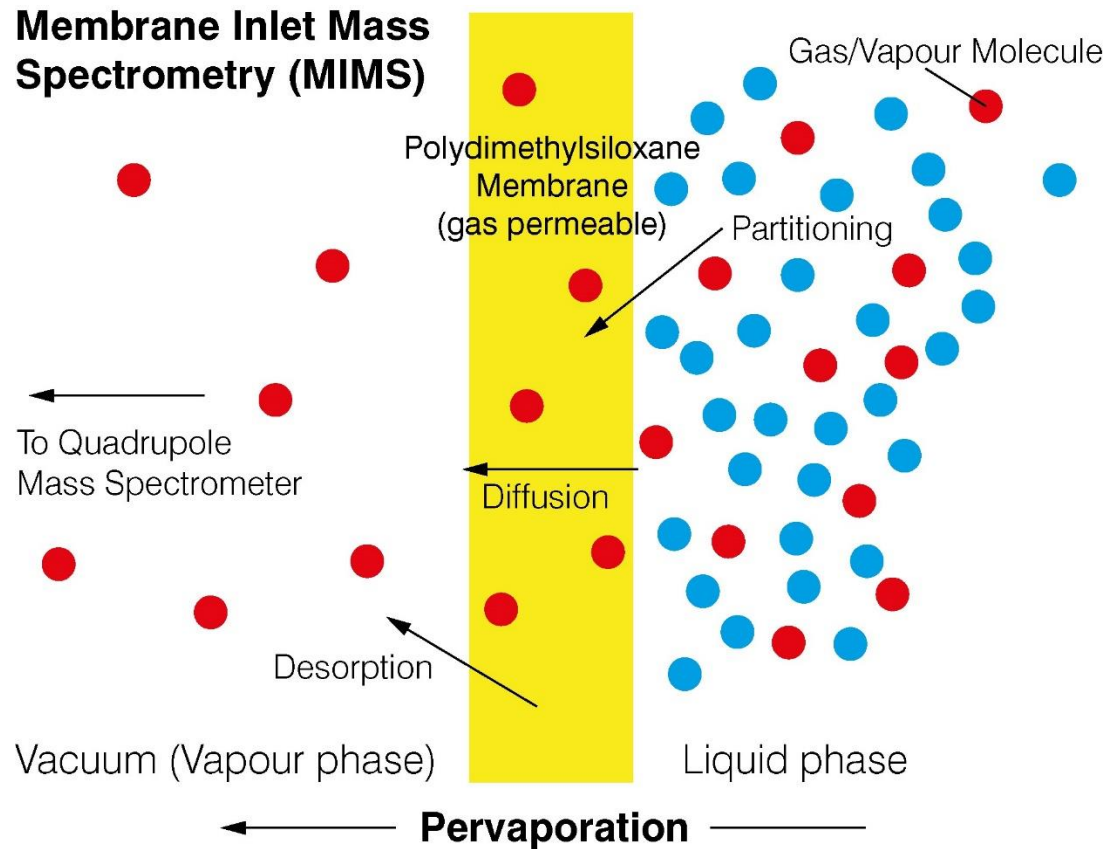

Typical enrichment factors w.r.t. N ₂	
CO ₂	12.0
CH ₄	3.2
C ₃ H ₈	13.6
CH ₃ OH	46.4
SO ₂	50.0
C ₃ H ₆ O	19.6
C ₆ H ₅ CH ₃	30.4

Dissolved Species Membrane Probe

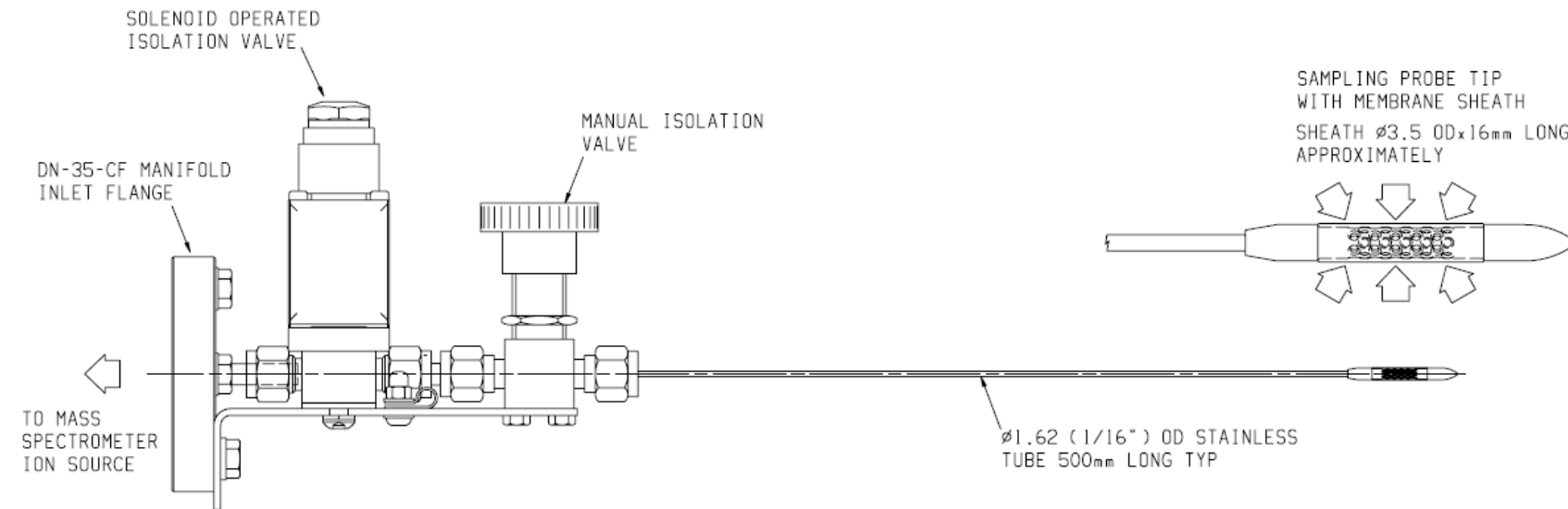

Flow-through Membrane Cell

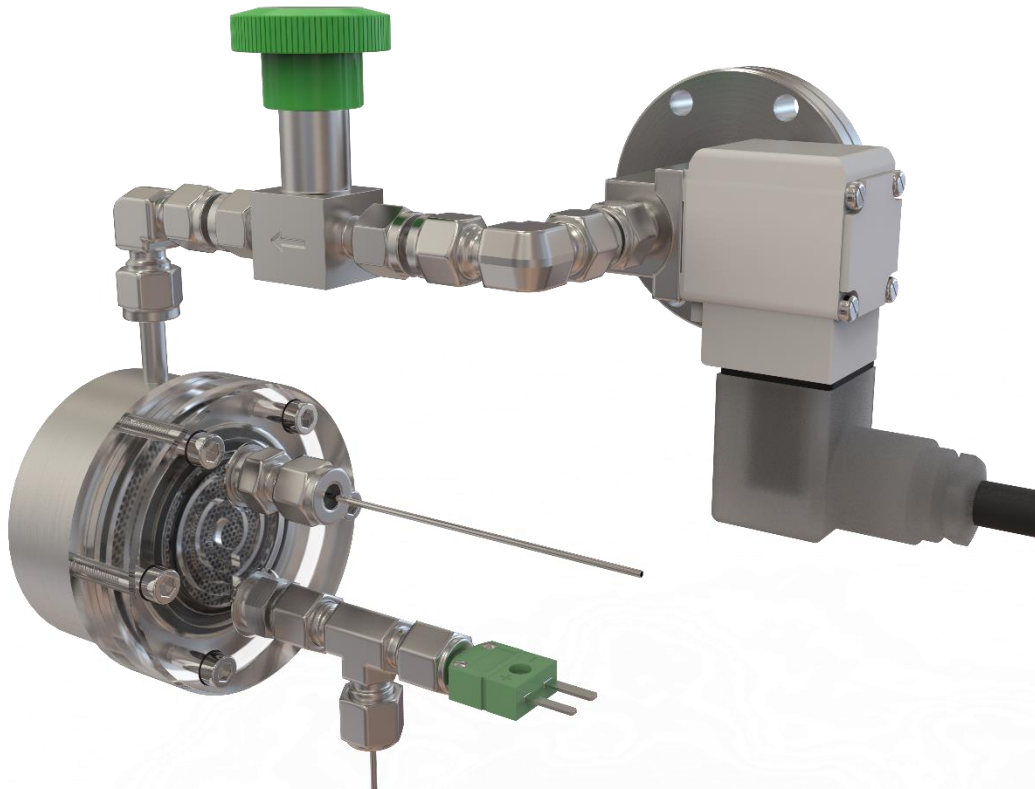

- Dissolved species flow-through membrane cell.
- Integrated thermocouple.
- Includes liquid flow connections, ideal for circulation applications.

Denitrification Inlet

- Flow through probe.
- Low flow design for denitrification studies.



Calibration Data

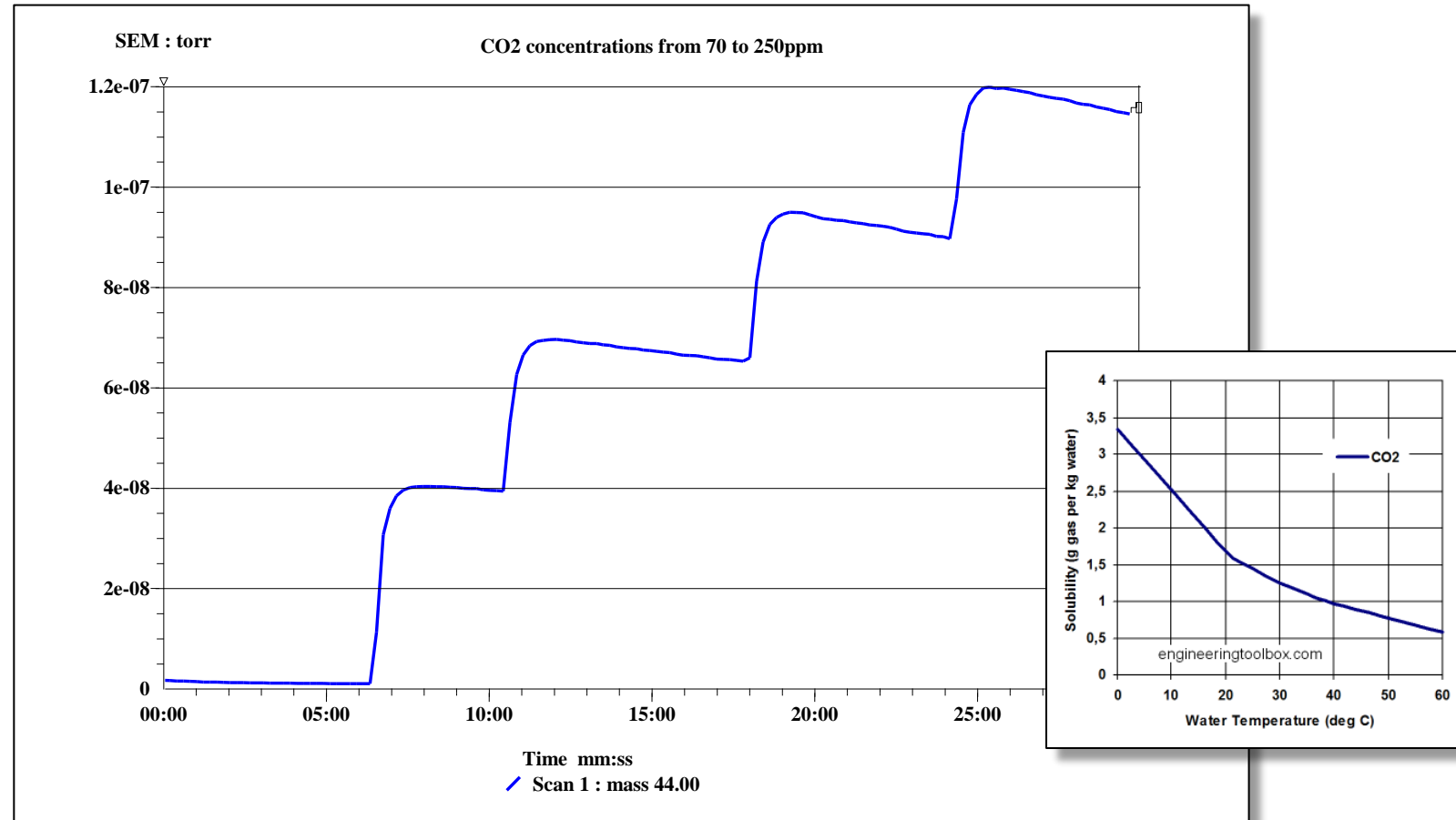

The figure shows the addition of 10mL aliquots of a CO₂-saturated H₂O solution (1.5g CO₂ per 1 kg H₂O at 23 °C as per inset graph) to 200 mL pure H₂O. Therefore, the concentrations of CO₂ are approximately 0, 70, 140, 200, and 250 ppm for the 5 time steps shown.

Application Example - River Studies

*p*QA used in a field study to dissolved species in river water, on site at Lez river, supplying drinking water to Montpellier, France.

Dissolved species in the water were measured using the membrane inlet, directly on the water samples taken at various parts of the river.

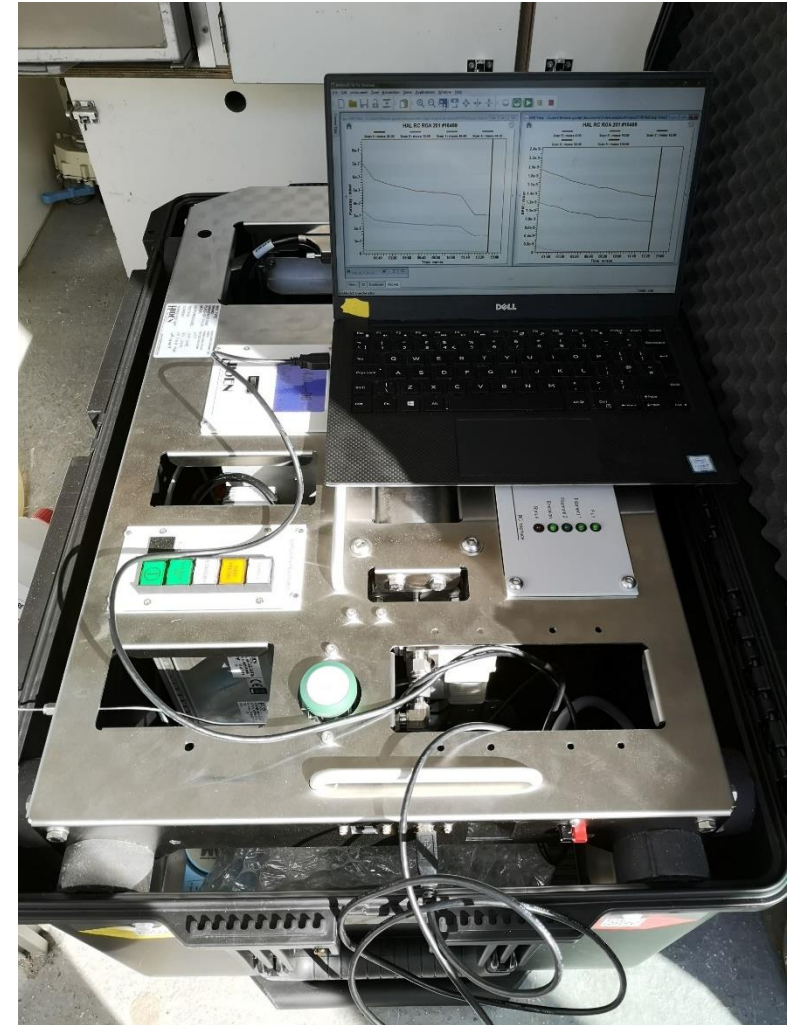

Quadrupole Mass Spectrometers for Advanced Science

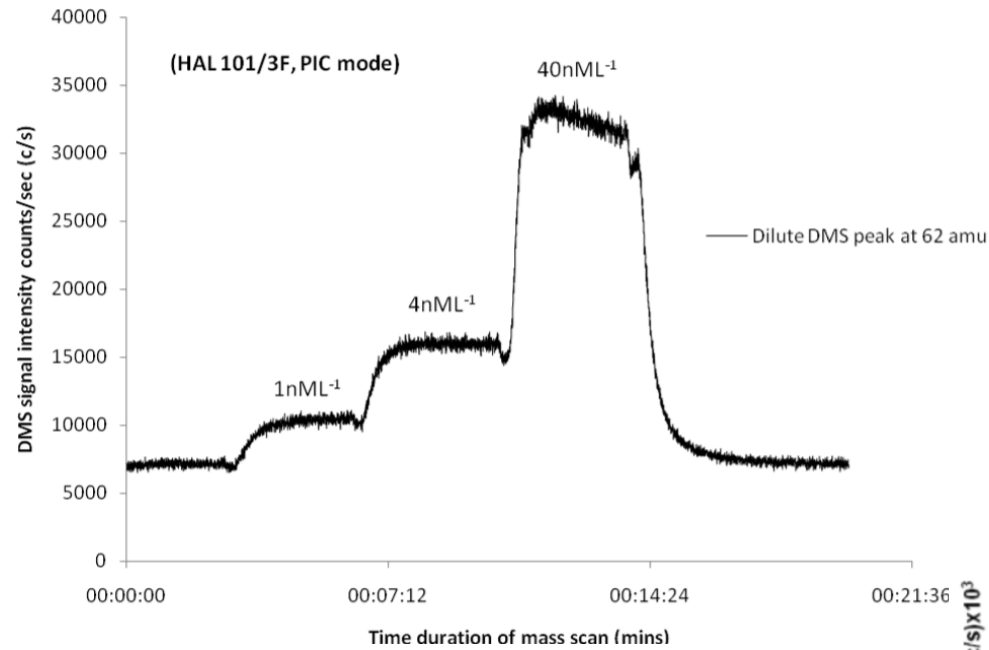

Data obtained shows sub ppb detection levels (≤ 60 ppt)

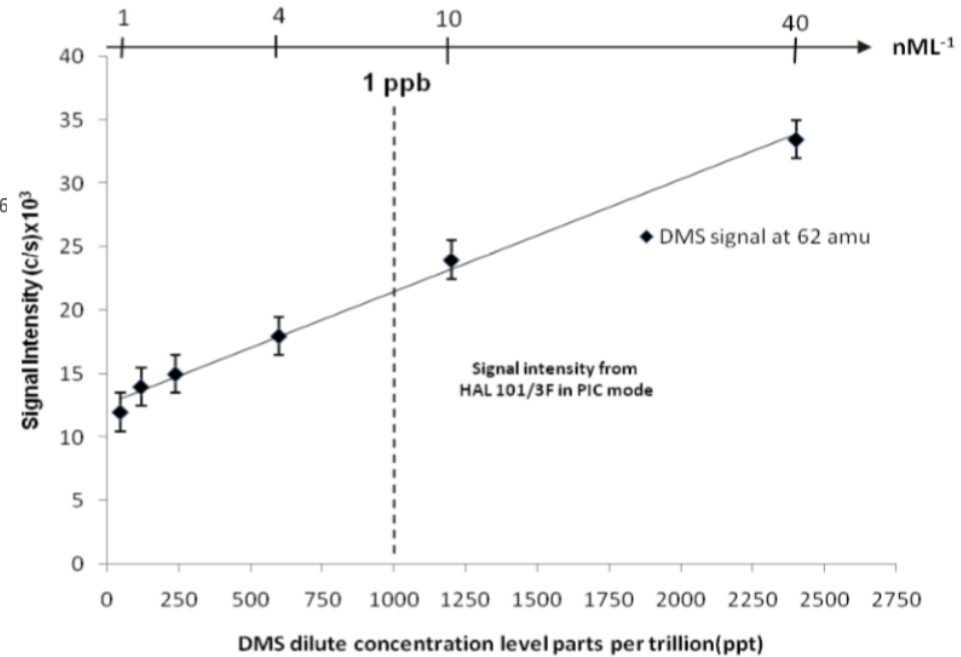

Data obtained with assistance from P.D. Tortell, Department of Botany, University of British Columbia

Denitrification study

Continuous real-time measurement of gases enabled the dynamics of the decomposition of Hypobromite Iodine solution to give Nitrogen gas was investigated.

Rate of denitrification dependant on concentration and required MIMS to measure.

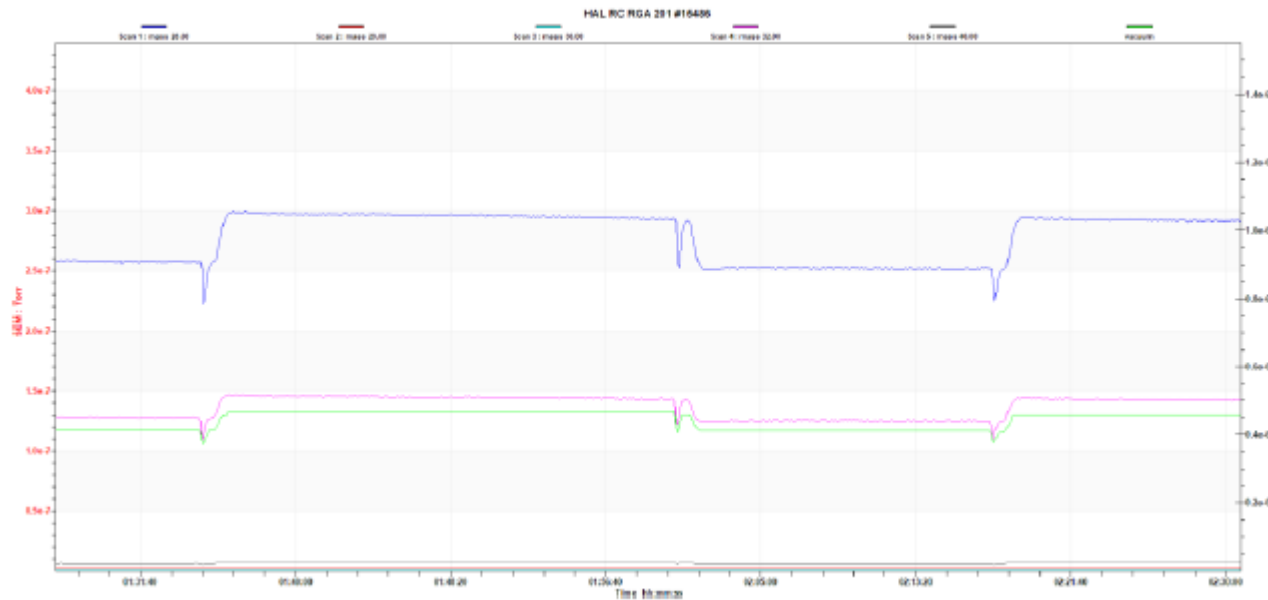

Denitrification data gathered by
Dr Hou, Dr Hong, Gangzhou Univ

Data Obtained in Denitrification Studies

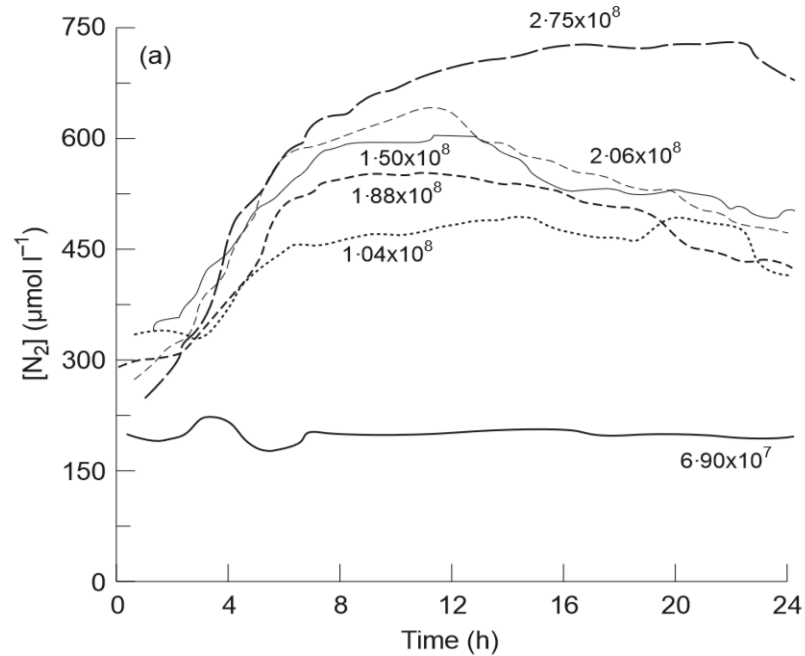

Data shows the effect of cell concentration on denitrification by *Pseudomonas stutzeri*. The lowest change in N_2 level measured was $40 \mu\text{mol l}^{-1}$ (Figure (a)).

Figure (b) demonstrates that a cell density in excess of $2 \times 10^8 \text{ cells ml}^{-1}$ did not unduly increase the amount of N_2 produced.

Data obtained by JR Firth and C Edwards, School of Biological Sciences, University of Liverpool, UK

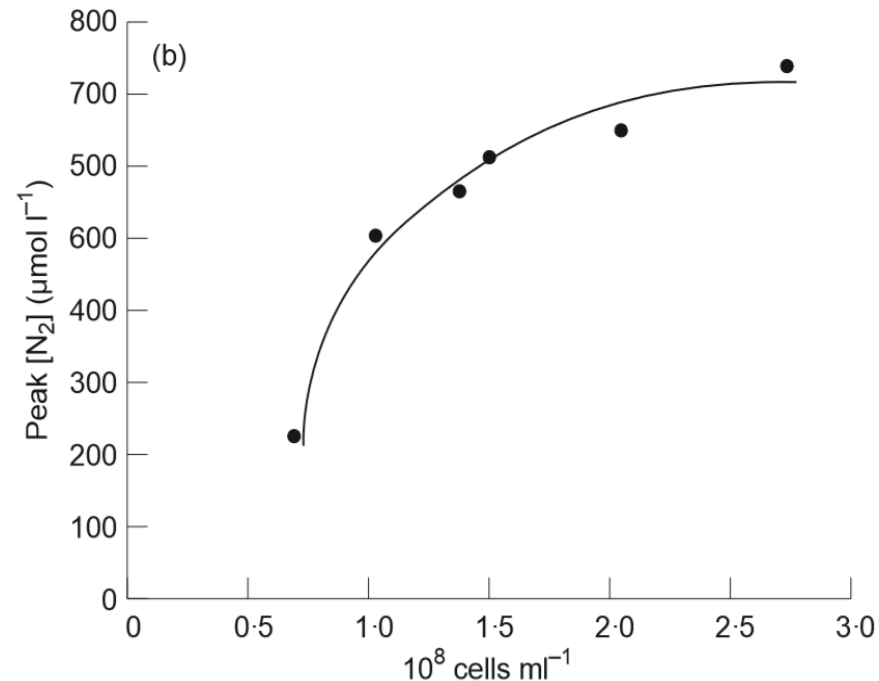



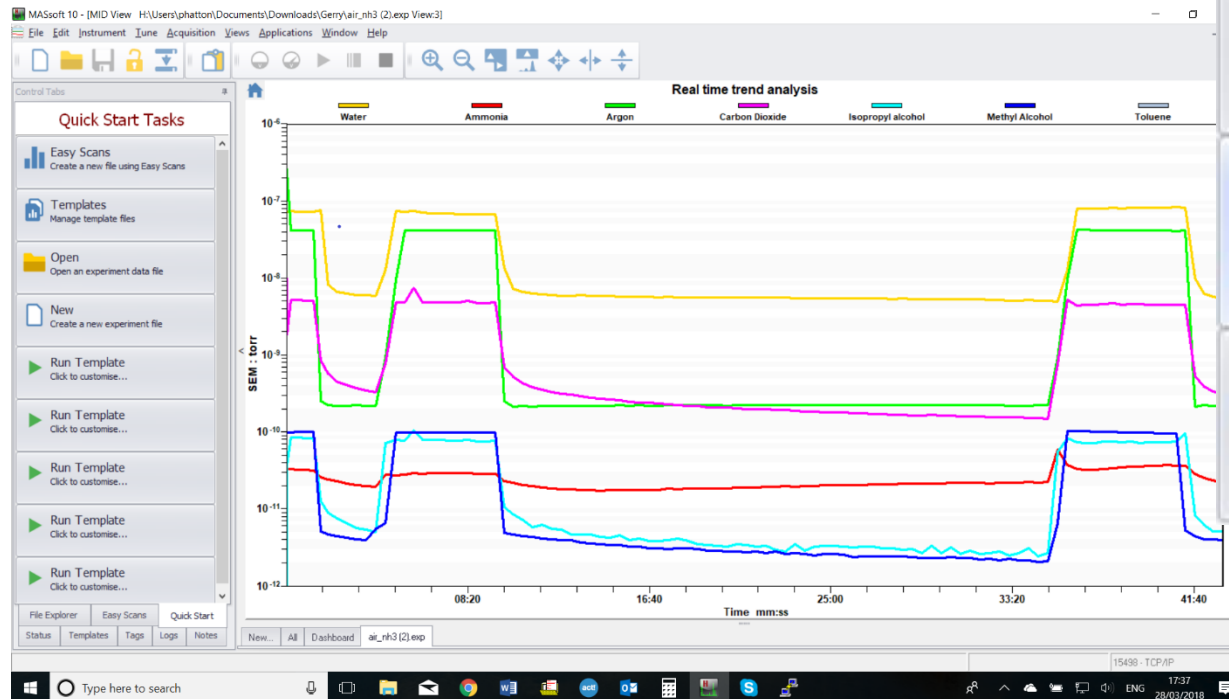

MASsoft Professional control software

- Template driven quick start operation
- Real time data display
- Mixed mode scanning including trend analysis
- Statistical analysis and peak integration
- Integrated mass spectral library



Easy Scans

-  **Profile Scan**
Display the shape of peaks across a range of masses
-  **Bar Scan**
Displays a histogram of peak intensities across a range of
-  **MID Scan**
Multiple Ion Detection Mode. Measures selected
-  **Leak Detect Scan**
Provides and audible and visual

Summary

- Membrane Inlet Mass Spectrometer for Dissolved Species Analysis
- Configurable species probe inlets can be used for a wide variety of scientific applications
- Designed and manufactured by Hiden in the UK

Academic References

- Denitrification by *Pseudomonas stutzeri* in a sterile lake water microcosm supplemented with succinate and nitrate. JR Firth and C Edwards *Journal of Applied Microbiology* 2000 **88** 853-859.
- Development of membrane inlet mass spectrometry for examination of fermentation processes. J-R Bastidas-Oyanedel, Z Mohd-Zaki, S Pratt, J-P Steyer and DJ Batstone *Talanta, The International Journal of Pure and Applied Analytical Chemistry* 2010 **83** 482-492.
- Influence of regional climate forcing on surface water pCO₂, DO₂ /Ar and dimethylsulfide (DMS) along the southern British Columbia coast. PD Tortell, A Merzouk, D Ianson, R Pawlowicz and D Yelland *Continental Shelf Research* 2012 **47** 119-132.
- High resolution measurement of Southern Ocean CO₂ and O₂/Ar by membrane inlet mass spectrometry. C Gu ´ eguen and PD Tortell *Marine Chemistry* 2007 **108** 184-194.
- Field Continuous Measurement of Dissolved Gases with a CF-MIMS: Applications to the Physics and Biogeochemistry of Groundwater Flow. E. Chatton, T. Labasque, J. de La Bernardie, N. Guihéneuf, O. Bour, L. Aquilina *Environ. Sci. Technol.* 2017, **51** (2) 846-854.

Applications

- Methane stimulates massive nitrogen loss from freshwater reservoirs in India, SIR-National Institute of Oceanography, Goa, India, Max-Planck Institute for Marine Microbiology, Bremen, Germany, National Oceanography Centre, University of Southampton, UK.
- Oceanic Trace Gas Measurements by Membrane Inlet Mass Spectrometry (MIMS), University of British Columbia, Institute of Ocean Sciences - Fisheries and Oceans, Canada, Universities of California, Delaware, and Charleston, USA.
- Diurnal variation of stream denitrification in a southeast China coastal watershed, Coastal and Ocean Management Institute, Xiamen University, China, Dept. of Water Resources Engineering, Lund University, Sweden.
- Enhancing denitrification using a carbon supplement generated from the wet oxidation of waste activated sludge, University of Queensland, Australia, Sustainable Design, Scion, New Zealand.
- The impact of sludge amendment on gas dynamics in an upland soil: Monitored by membrane inlet mass spectrometry (MIMS), University of Bath, UK.
- Ground water study of 5 biologically /chemically inert gases - He, Ne, Ar, Kr, Xe - and their reaction to physical external forces in the environment, www.critex.fr

Hidden MIMS Users



廈門大學
XIAMEN UNIVERSITY

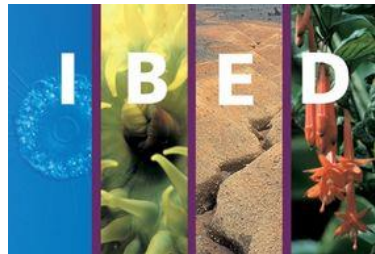

UNIVERSITY OF
EASTERN FINLAND



UNIVERSITY OF
LIVERPOOL

- Trent University
- Forest Research Institution (SCION)
 - Xiamen University
 - University of Kuopio
 - Cardiff University
 - University of Wales
 - Ricoh
 - University of Queensland
 - University of Newcastle
- University of California, Berkeley
 - Liverpool University
- Institute for Biodiversity and Ecosystem Dynamics
 - National Institute of Oceanography, Goa
 - GBA Laborgruppe
 - University of Rennes



- www.HidenAnalytical.com
- The Hiden website is an excellent resource with product pages, brochures, catalogues, product pages with some application notes, presentation and other information.
- Contact +44 1925 445225 for direct support.